

Julius Kahle

RWTH Aachen University

Architecture & Tools

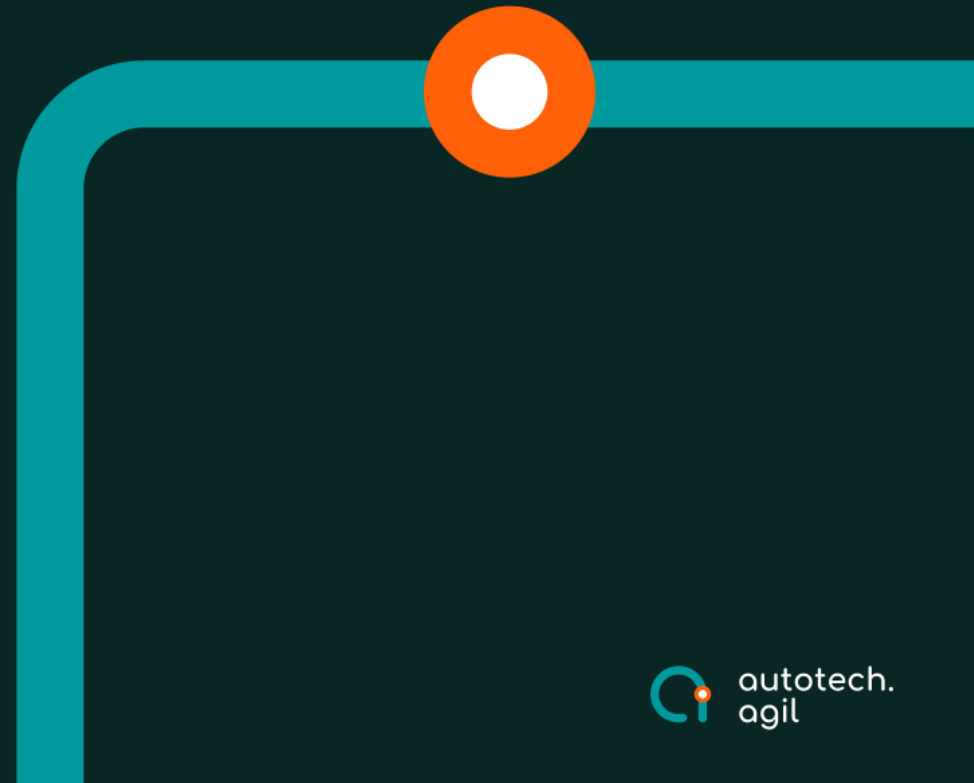

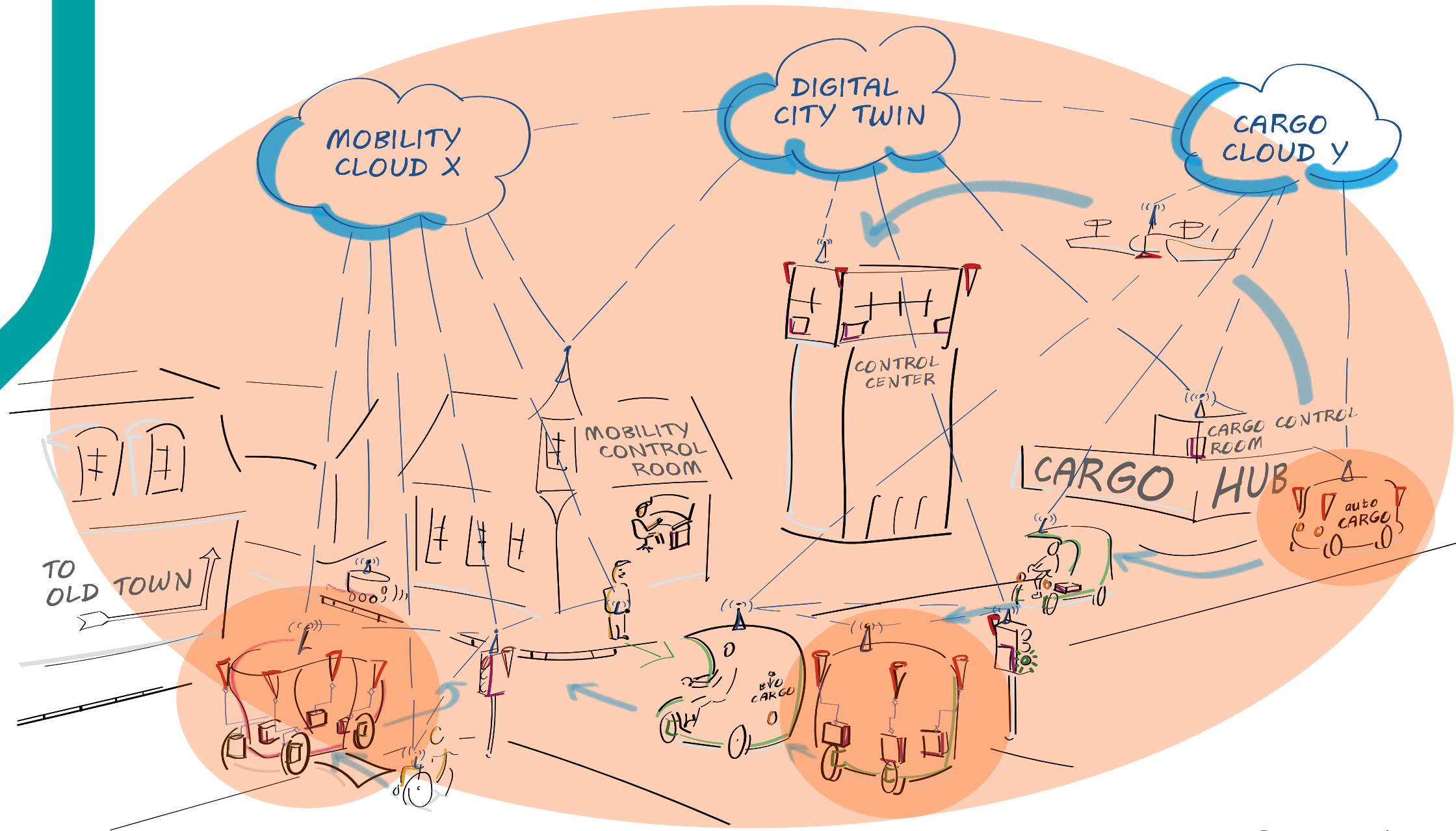

Automotive Service-Oriented Architecture (ASOA)

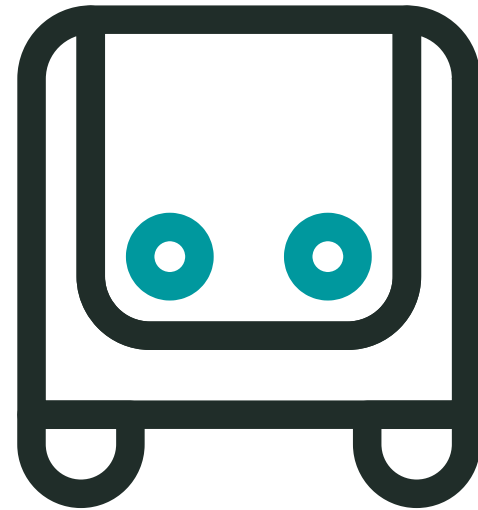

Automotive Service-Oriented Architecture (ASOA)

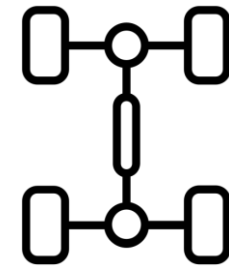
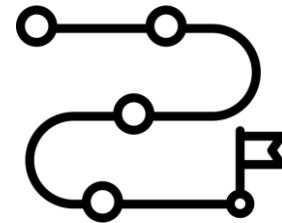
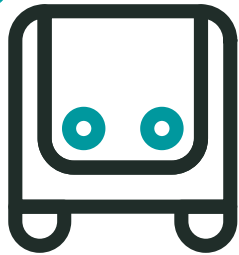

Automotive Service-Oriented Architecture (ASOA)

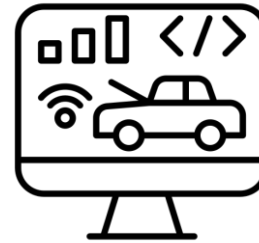
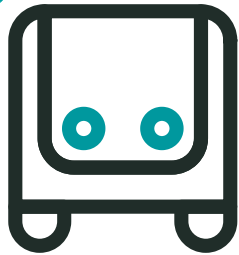

Automotive Service-Oriented Architecture (ASOA)

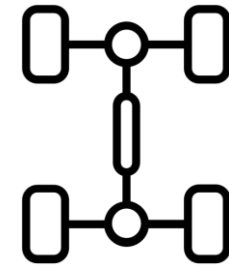
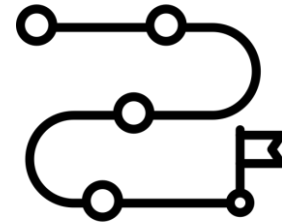
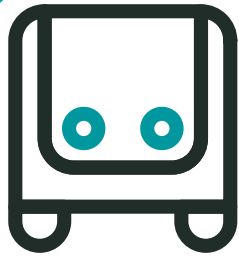

Automotive Service-Oriented Architecture (ASOA)

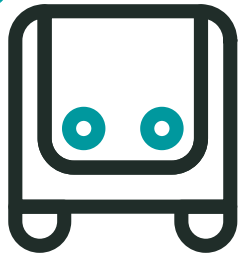

Effect Chain

Automotive Service-Oriented Architecture (ASOA)

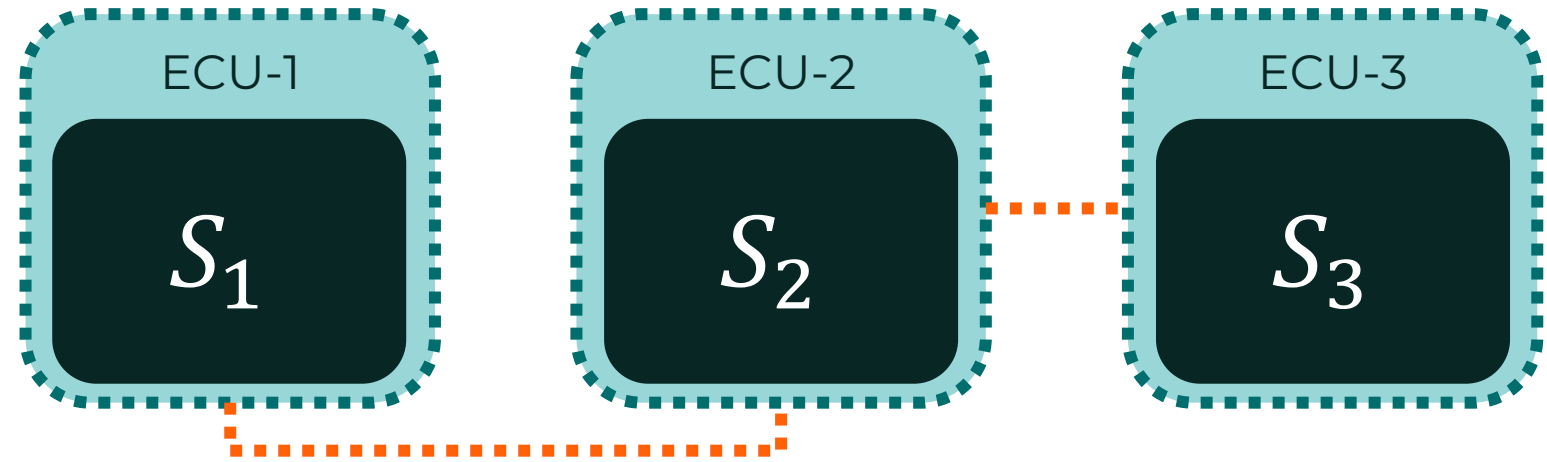
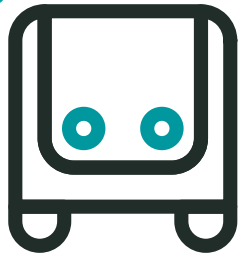

CAN, LIN, FlexRay

Automotive Service-Oriented Architecture (ASOA)

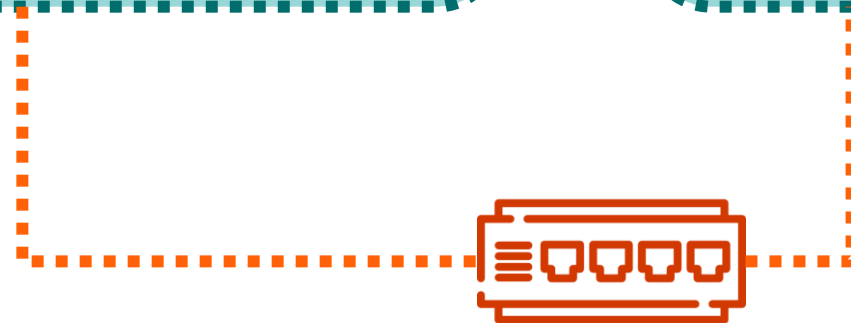
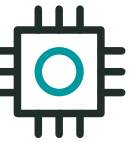
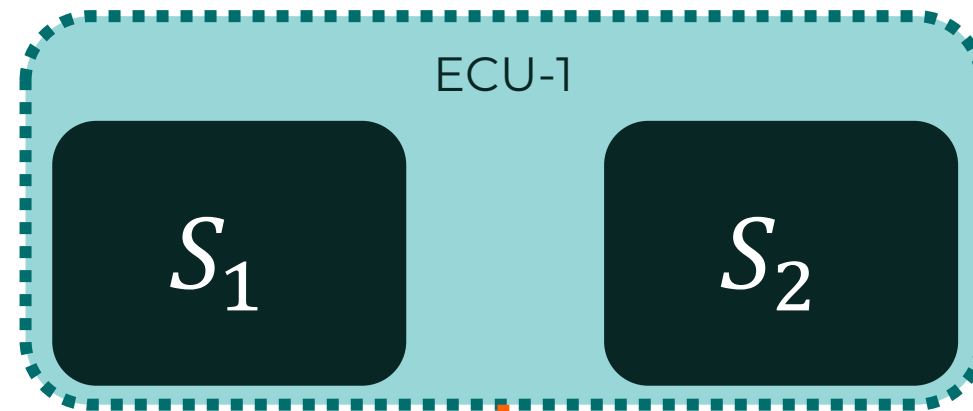
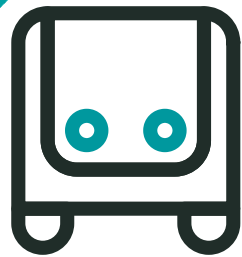

Automotive Ethernet

Automotive Service-Oriented Architecture (ASOA)

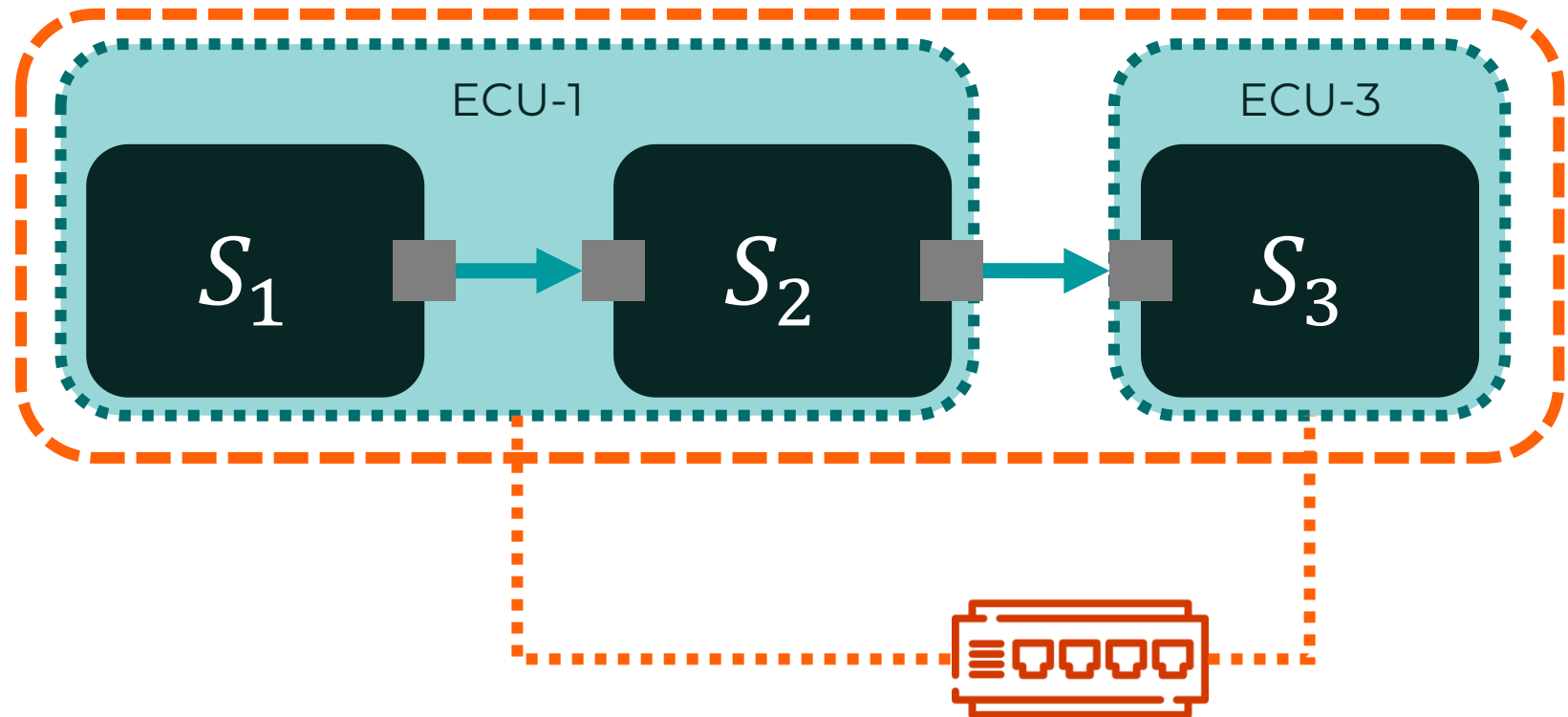

ASOA Orchestrator

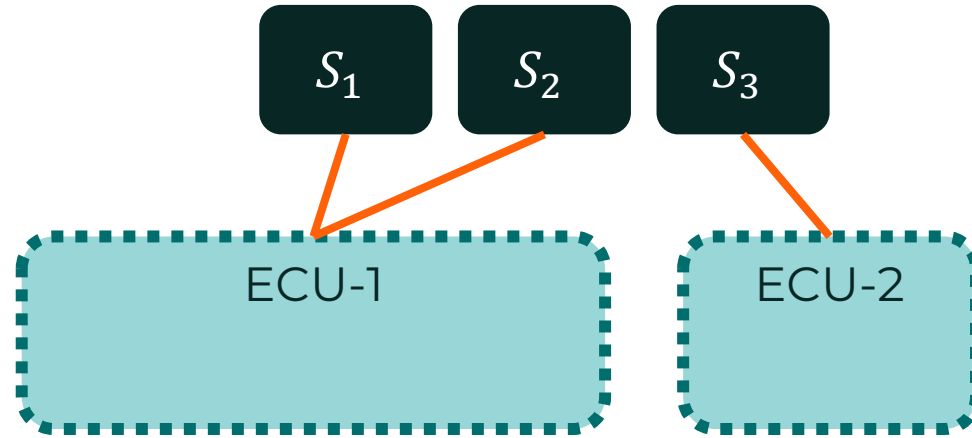

Resource
Orchestration

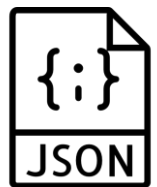

Declarative
Orchestration

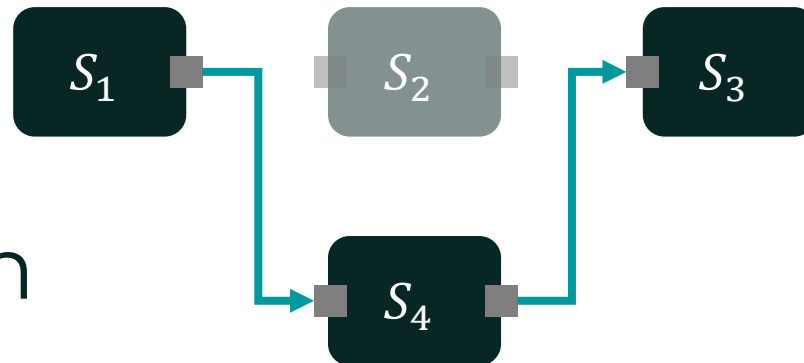

Functional
Orchestration

Performance Assessment and Management

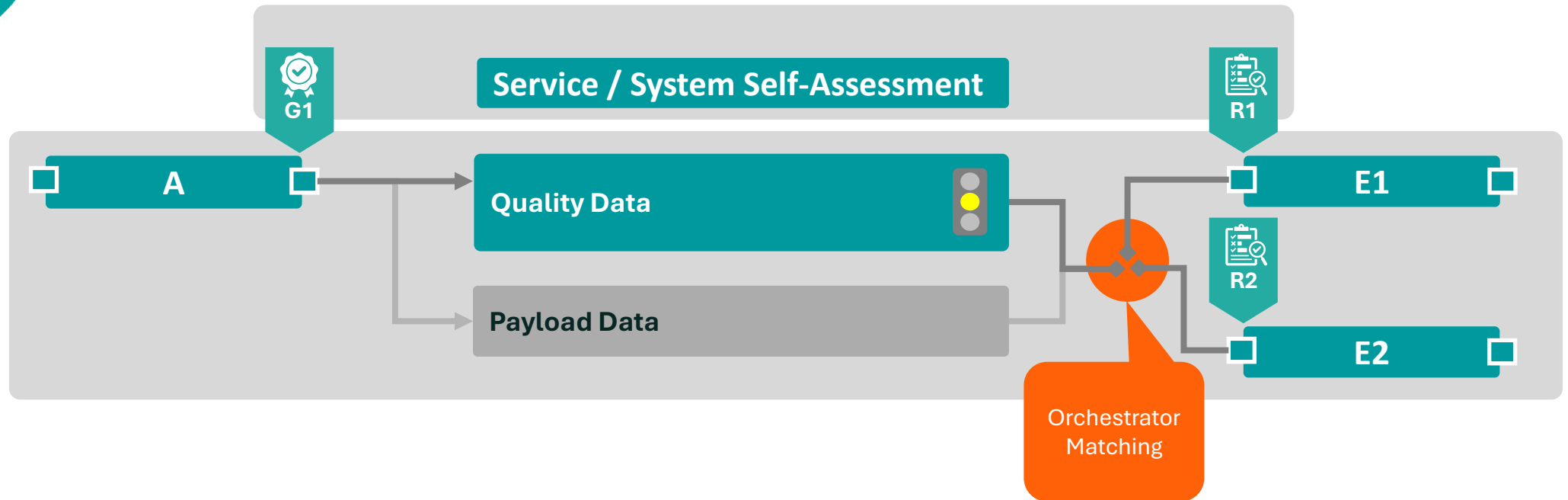

Automotive Service-Oriented Architecture (ASOA)

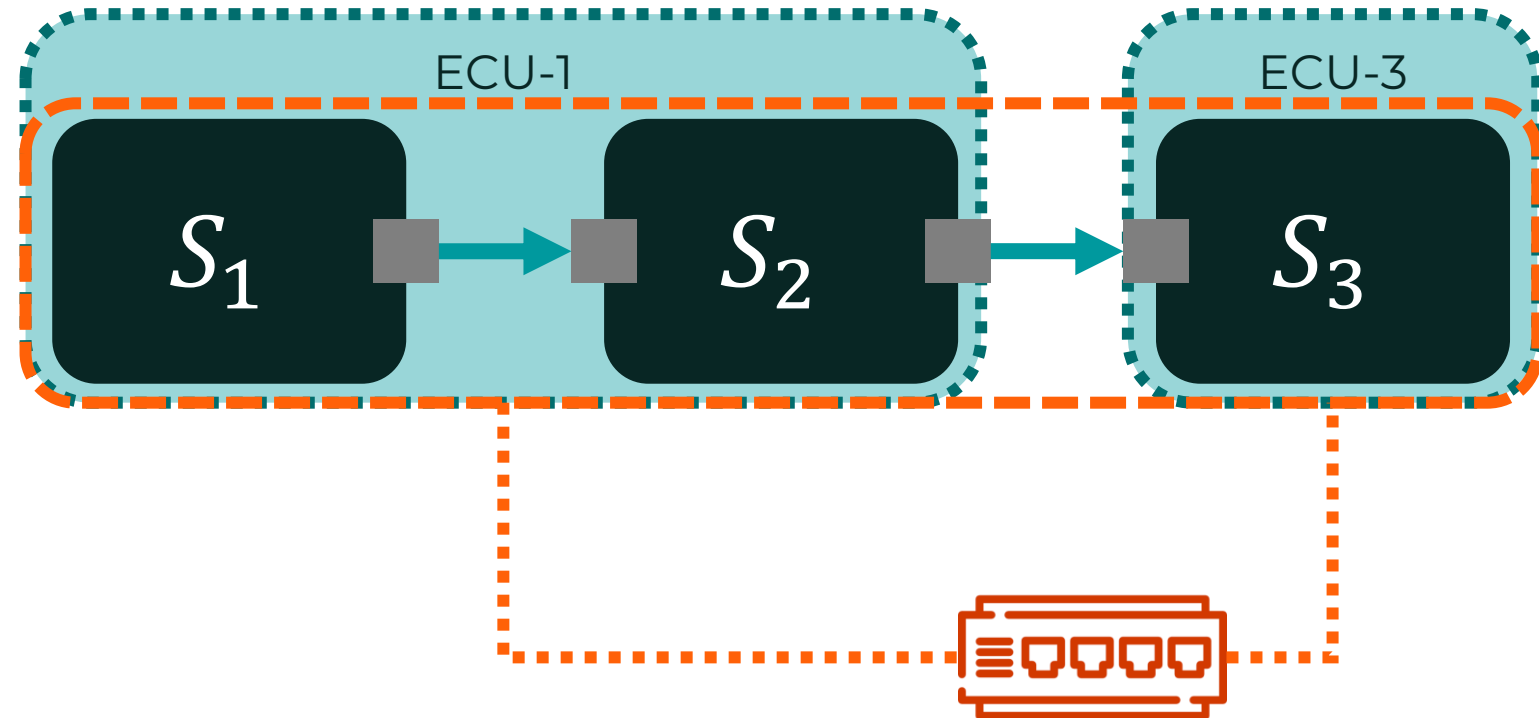

Tracing Inter-service Communication Paths

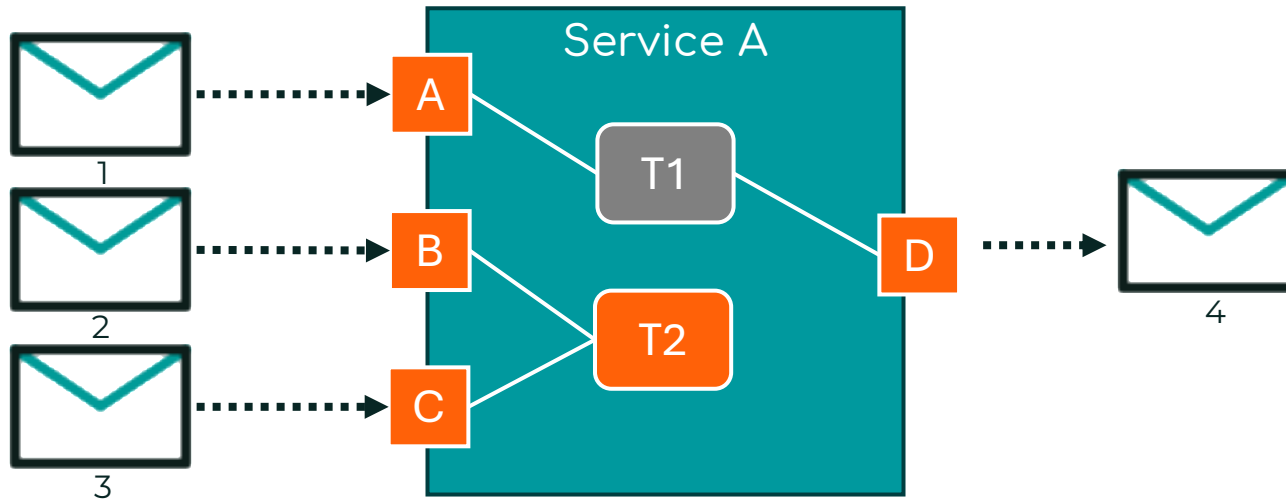

Correlation Mapping

Received Messages:

<A, 1>

<B, 2>

<C, 3>

Sent Message:

<D, 4>

Automotive Service-Oriented Architecture (ASOA)

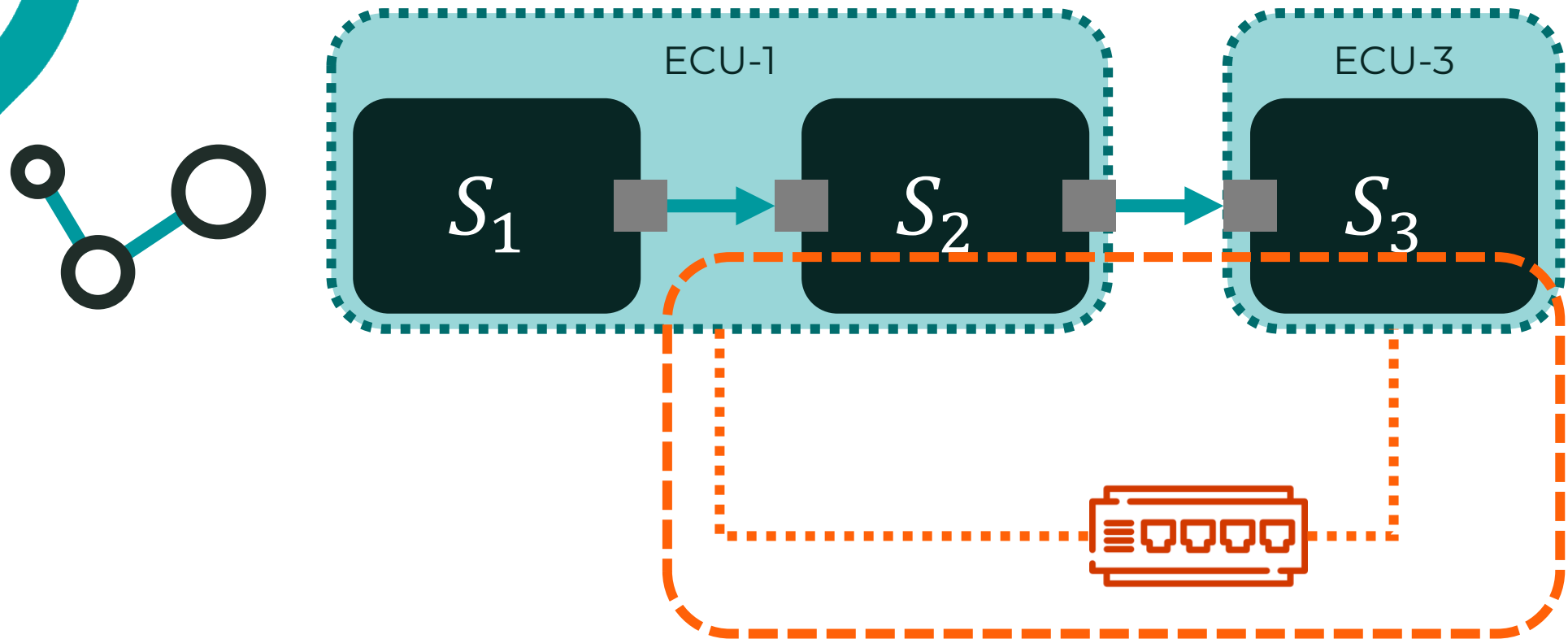

Deterministic Communication

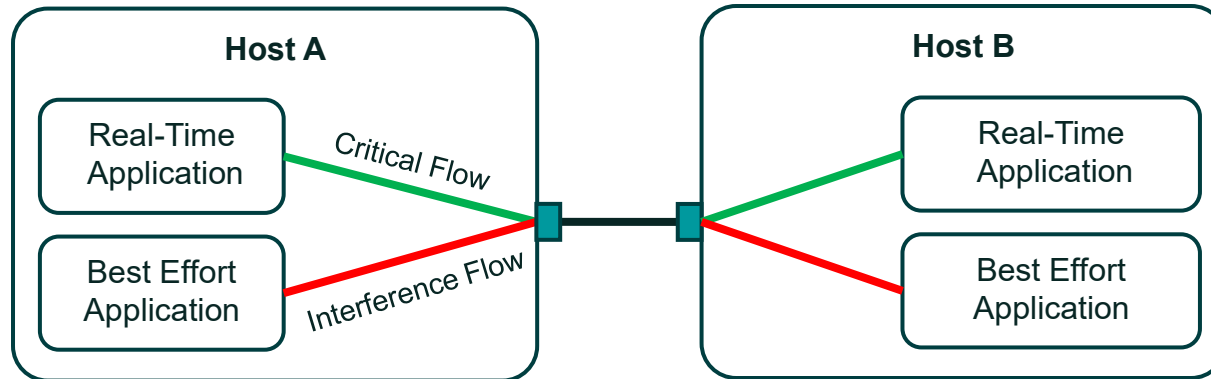

Mixed-criticality

Deterministic Communication

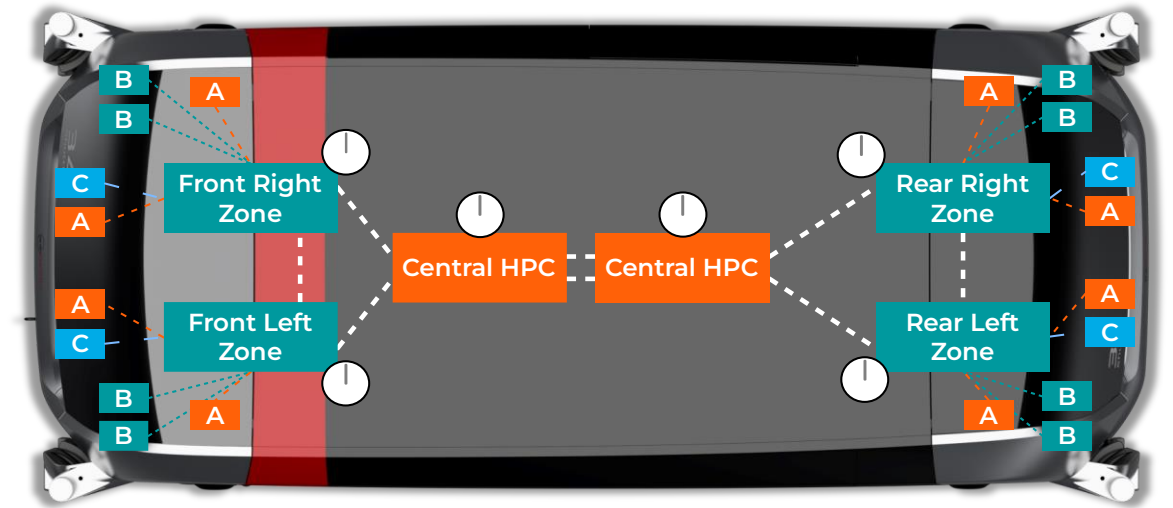
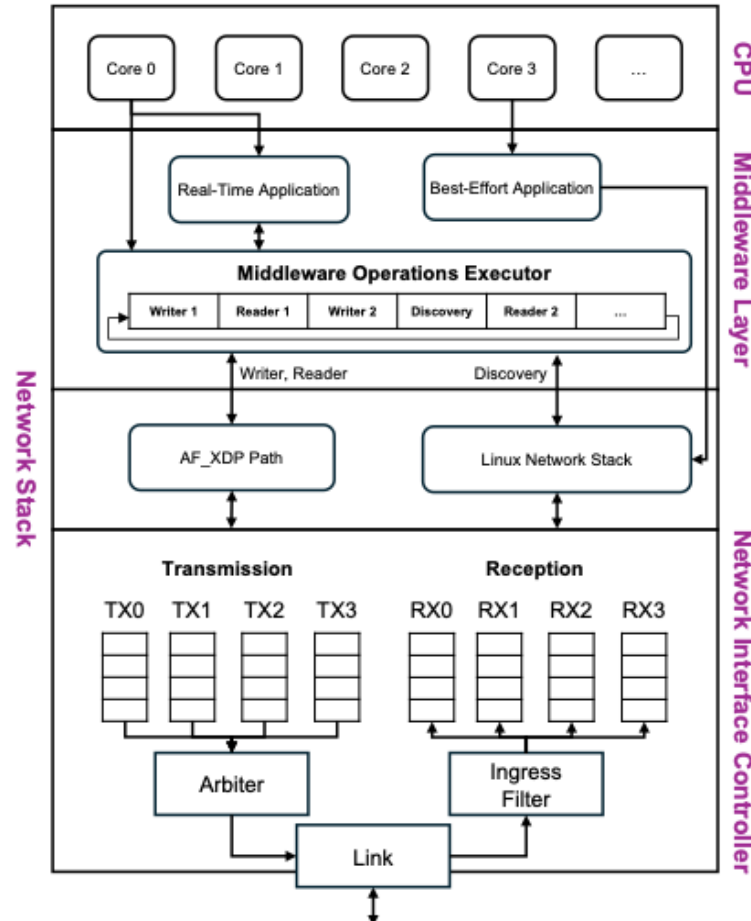

Time Sensitive Networking

Timing Isolation Architecture

Automotive Service-Oriented Architecture (ASOA)

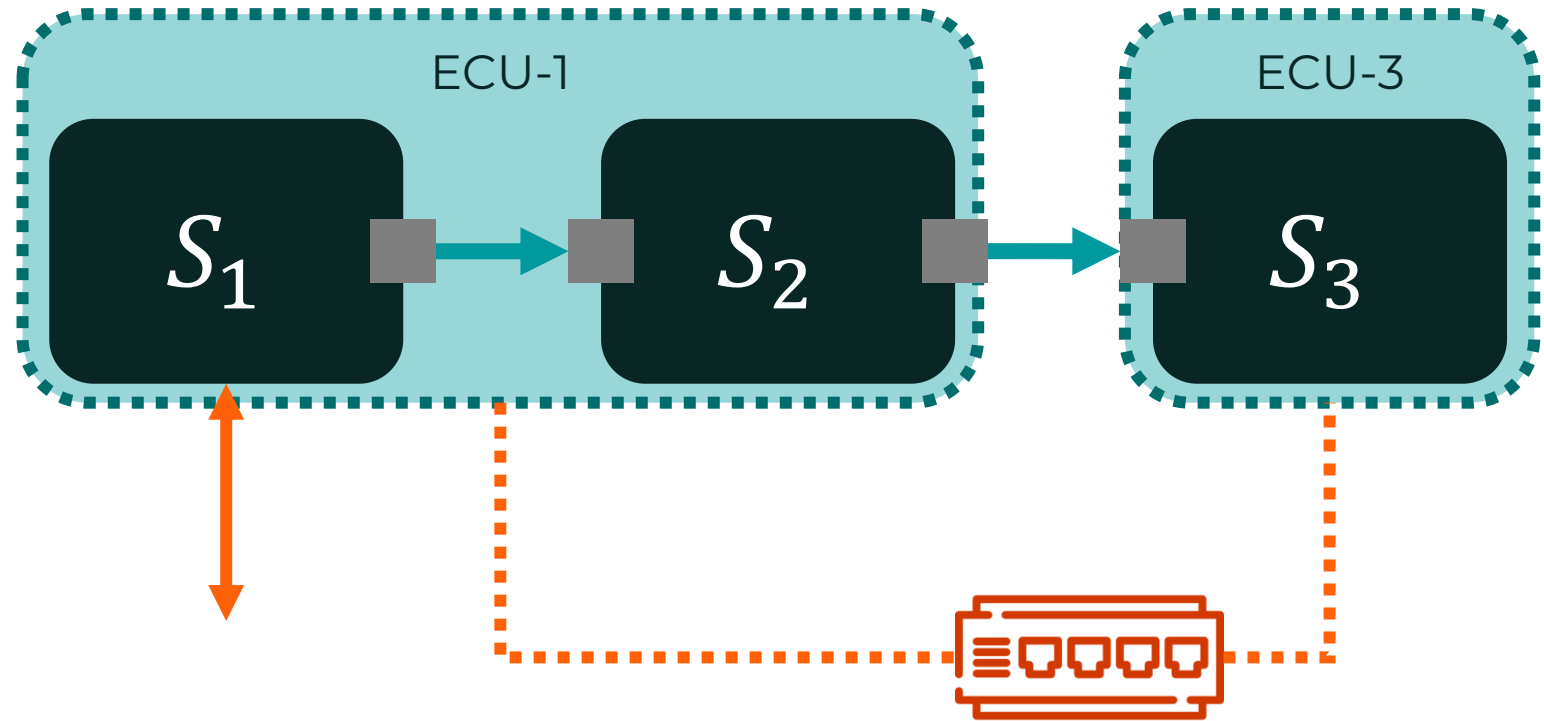

Service-Oriented Function Offloading

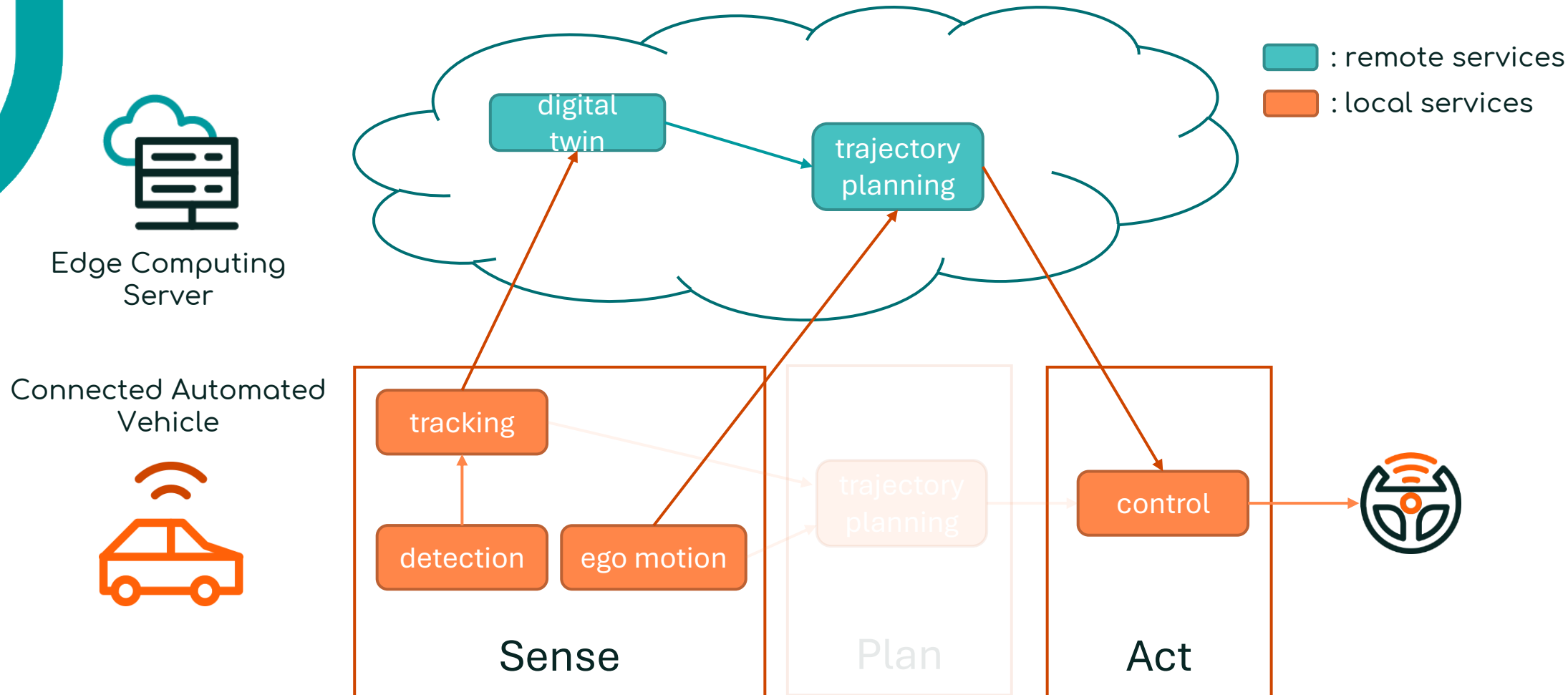

Automotive Service-Oriented Architecture (ASOA)

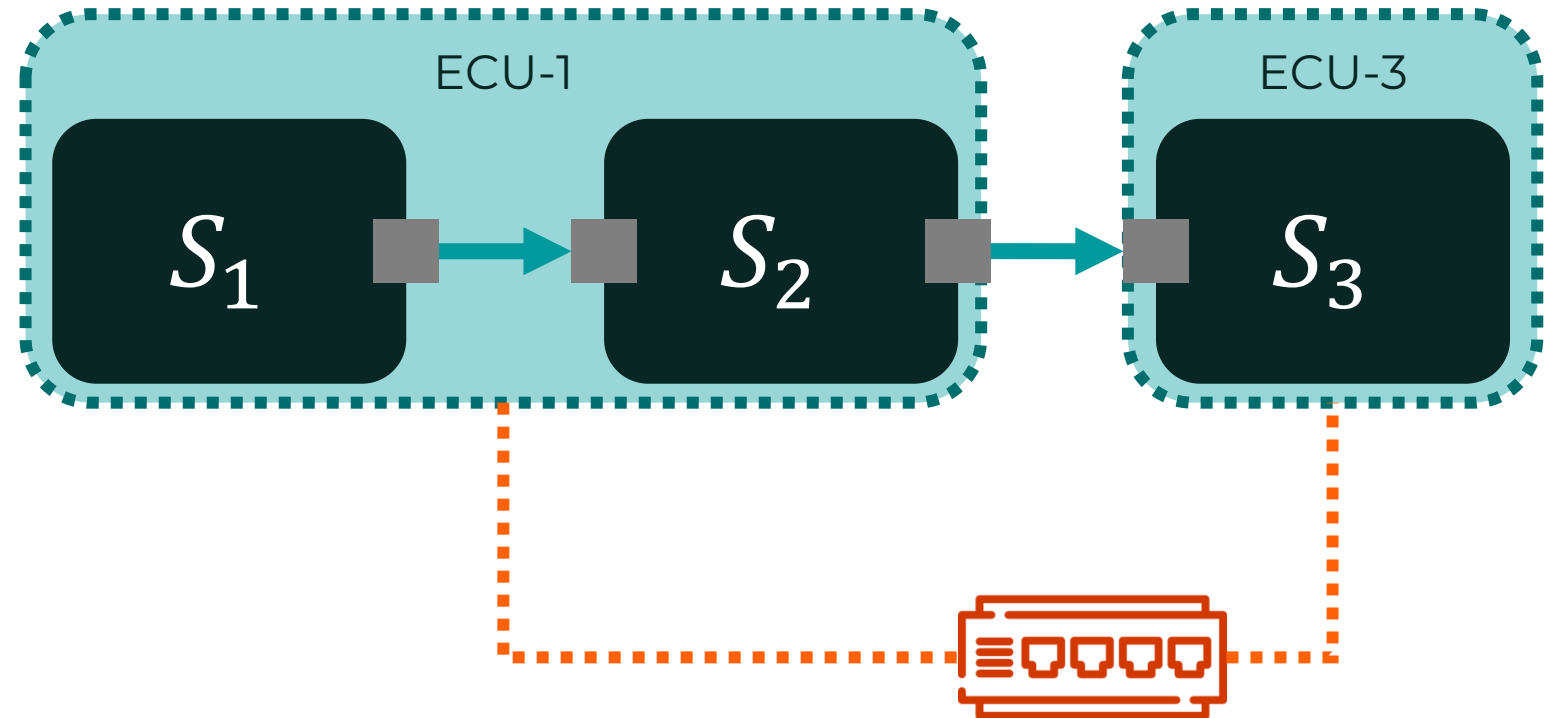
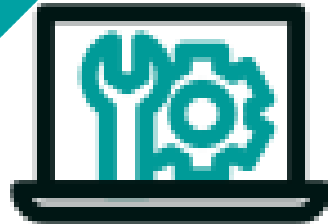

Continuous Integration and Qualification Framework

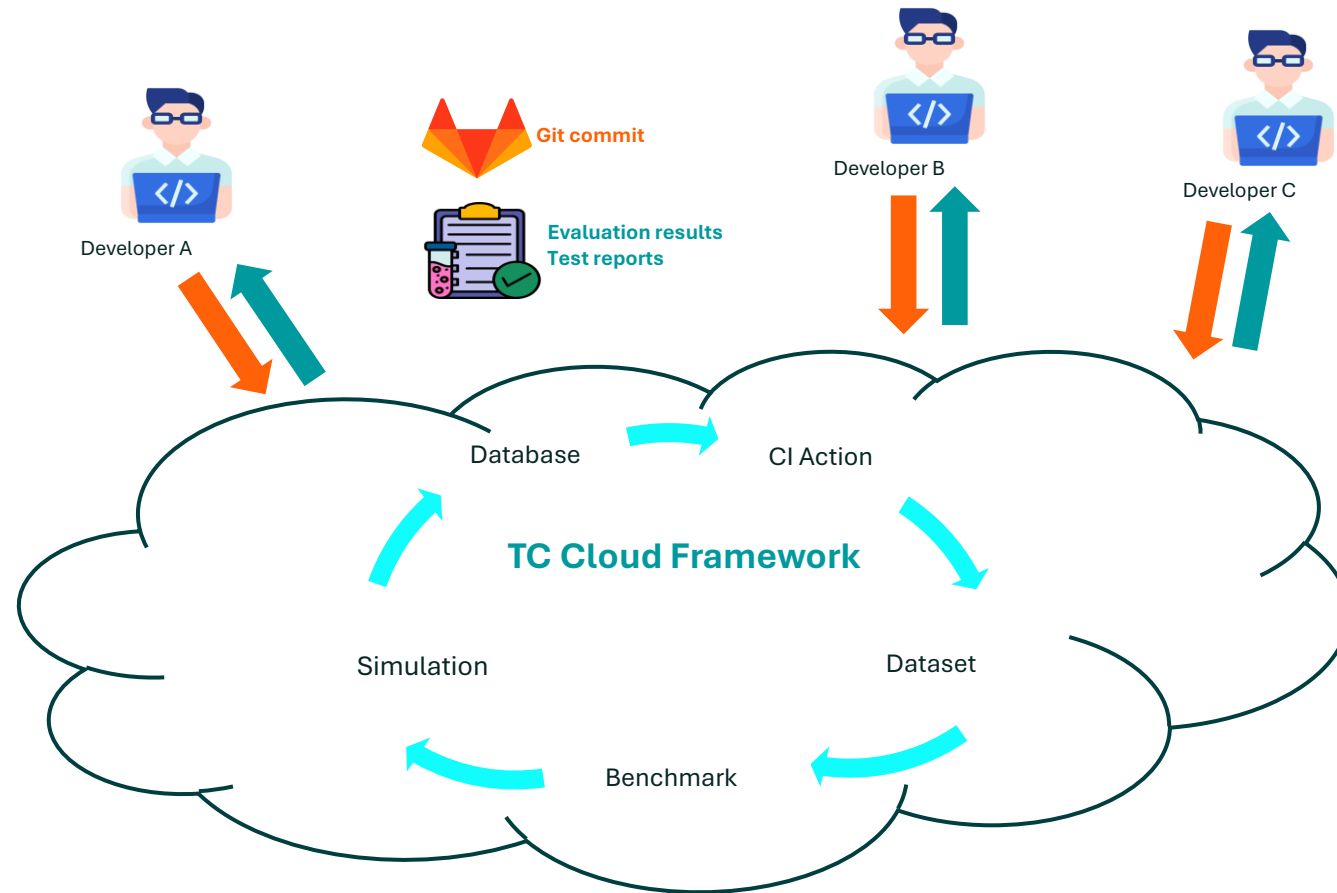

Architecture Specification Tool

architektur.autotechagil.embedded.rwth-aachen.de

SUCHEN

autoSHUTTLE

- User Dashboard
- Architektur Management
- Sichten:**
- Funktionale Architektur**
- Dienste Architektur
- Steuergeräte Architektur
- Energiebordnetz
- Thermisches Bordnetz
- Leistungsaktuatoren
- Cloud
- Logische Architektur machine-hearing
- Logische Architektur well-being
- Dienste Architektur machine-hearing
- Dienste Architektur well-being
- Module:**
- Dynamikmodul
- Sensormodul

Sicht: Funktionale Architektur

Beschreibung
Die funktionale Architektur im UNICARagil Projekt

Graph

Inkonsistente Verbindungen

INPUT	INPUT-KOMPONENTE	OUTPUT	OUTPUT-KOMPONENTE
Verarbeitete Daten	Plattformumfeldrepräsentation	Verarbeitete Daten	Datenverarbeitung
Fahrzeug Umfeldmodell	Situationsprädiktion	Fahrzeug-Umfeldmodell	Fahrzeugumfeldmodell

And so much more...

- Deterministic Coupling of AUTOSAR Classic and Adaptive using SL-LET
- Common Interfaces with ROS and ETSI ITS Messages
- Toolchain for Deployment, Simulation & Operation

...